

# Explosion-proof Duct Heaters

## Safety

INDEECO explosion-proof ULTRA-SAFE™ and EP2 duct heaters are Factory Mutual (FM) and CSA Approved. The ULTRA-SAFE™ duct heater has the only standard product offering and features the industry's lowest ignition temperature code rating, T3C, 320°F (160°C).

## Experience

This catalog represents more than 70 years experience in industrial electric heating, our specialty since INDEECO was founded in 1929. INDEECO has more than 50 years experience with forced air comfort heating for hazardous locations.

## Complete Product Line

- Industry's most comprehensive product line of space heating equipment.
- Ratings up to 750 KW and 600 volts.
- Widest selection of built-in controls.

## Applications

INDEECO Duct Heaters provide a clean, safe source of electric heat for comfort heating and freeze protection in hazardous locations where specific explosive gases or dusts are present, and environments where moisture and corrosion exist.

## Use of Electric Heaters in Hazardous Areas

Electric heating equipment can be economically designed and safely used in hazardous areas if the following special requirements are kept in mind.

1. The surface temperature of the electric heating equipment cannot exceed the ignition temperature of the hazardous atmosphere. To insure that the proper heater has been selected, it is essential that the correct NEC Ignition Temperature Code be specified (see **Table XVI**). If the Temperature Code selected is too high, the electric heating system may operate above the ignition point of the application, creating a potentially hazardous condition.
2. All arc and spark producing control devices must be isolated from the hazardous atmosphere. If it is not economically feasible to locate the control devices in a non-hazardous area, they must be housed in an enclosure that will withstand the pressure of a potential explosion from within the enclosure.
3. All electrical supply connections must be made according to the latest NEC and local code requirements for hazardous locations. This includes the requirement that conduit entering the enclosures must be provided with seals at the enclosure.



# Explosion-proof Duct Heaters

Hazardous locations are those areas where a potential for explosion and fire exists due to the presence of flammable gases, vapors, pulverized dusts, or ignitable fibers in the atmosphere. Hazardous locations are created from the normal processing of volatile chemicals, gases, coal, grains, etc., or from the accidental failure of storage systems for these materials.

Both people and equipment in hazardous locations can be heated safely and economically with electric heat. Electric heating is typically much less expensive to install and maintain than comparable remote oil or gas fired heating systems.

**Table XVI**  
**Ignition Temperature**

Maximum Surface Temp. Of Heater*		NEC Ignition Temp. Code
°C	°F	
450	842	T1
300	572	T2
280	536	T2A
260	500	T2B
230	446	T2C
215	419	T2D
200	392	T3
180	356	T3A
165	329	T3B
160	320	T3C

\*All electrical equipment is designed not to exceed the ignition temperature of the hazardous atmosphere. The maximum surface temperature for electric heaters is defined by the NEC for each class as indicated above.

## National Electrical Code Classification

Articles 500 through 516 of the National Electrical Code deal with the definition of hazardous areas and the use or design of electrical equipment used in these locations. Electric heating equipment for hazardous areas is specified based on the NEC Class, Division, Group, and Ignition Temperature.

## Class

Hazardous locations are divided into the three general classes of vapors/gases, dusts, and fibers.

**Class I** – Locations where the potential for explosion and fire exists due to the presence of flammable gases or vapors in the air. Typical Class I locations include: oil or natural gas drilling rigs, petroleum refining or pumping facilities, petrochemical plants, wastewater/sewage treatment plants, solvent extraction plants, paint spraying booths, locations where open tanks or vats of combustible liquids are present, and storage areas for flammable materials.

**Class II** – Locations where the potential for explosion exists because of finely pulverized flammable dusts suspended in the atmosphere. Typical locations would include coal fired power plants, coal preparation/coal handling facilities, coal mines, grain elevators, flour and feed mills, packaging and handling of pulverized sugar, processing and storage of magnesium and aluminum powder.

**Class III** – This third classification is primarily a fire hazard where fibers or flyings suspended in the air create a hazard. This would include small pieces of thread like fiber, sawdust, lint, etc. Typical applications would include: textile mills, woodworking plants, cotton gins and cotton seed mills, and flax producing plants.

## Division

Class I, Class II, and Class III areas are further defined in terms of when the hazard occurs. Division 1 and Division 2 occurrences are summarized below:

**Division 1** – If the hazard is expected to be present under normal conditions, such as in a production or processing facility, the occurrence is designated Division 1. The hazardous atmosphere may be present continuously, intermittently, periodically, or during normal repair or maintenance operations. Division 1 occurrences also include locations where a breakdown in the operations of processing equipment results in the release of hazardous vapors.

**Division 2** – If the hazardous material is normally expected to be contained within a closed area, system or container and would enter the ambient atmosphere only under an abnormal failure, then it is referred to as a Division 2 occurrence.



www.indeeco.com  
800-243-8162

# Explosion-proof Duct Heaters

## Group

The nature and explosive characteristics of the hazardous material is defined by the NEC group to which it is assigned.

**Class I** – Hazardous gas locations include chemicals and other materials that have been divided into four groups based on their ignition temperature and explosive characteristics. (Groups A, B, C and D)

**Class II** – Hazardous dust locations are divided into three groups based on their ignition temperature and electrical conductivity of the suspended particles.

**Group E** – Atmospheres containing metal dusts such as aluminum and magnesium.

**Group F** – Atmospheres containing coal, charcoal, or coke dusts.

**Group G** – Atmospheres with grain, flour, starch, combustible plastics or chemical dusts.

**Class III** – Locations have no group definitions.

Table XVII

CLASS I – HAZARDOUS GAS ATMOSPHERES					CLASS I – HAZARDOUS GAS ATMOSPHERES (cont.)				
Group	Material	Ignition Temp.		NEC Code	Group	Material	Ignition Temp.		NEC Code
		°F	°C				°F	°C	
A	Acetylene	581	305	T2	D	Methyl Isobutyl Ketone	840	448	T2
B	Acrolein (Inhibited)	428	220	T2D		2-Methyl-1-Propanol (Isobutyl Alcohol)	780	415	T2
	Butadiene	788	420	T2		Petroleum Naptha	550	288	T2A
	Ethylene Oxide	804	429	T2		Pyridine	900	482	T1
	Hydrogen	932	500	T1		Octanes	403	206	T3
	Propylene Oxide	840	449	T2		Pentanes	500	260	T2B
	Propyl Nitrate	347	175	T3B		1-Pentanol (Amyl Alcohol)	650	343	T2
C	Acetaldehyde	347	175	T3B		Propane	842	450	T1
	Allyl Alcohol	713	378	T2		1-Propanol (Propyl Alcohol)	775	412	T2
	Carbon Monoxide	1128	609	T1		2-Propanol (Isopropyl Alcohol)	750	399	T2
	Cyclopropane	928	498	T1		Propylene	851	455	T1
	Ethylene	842	450	T1		Styrene	914	490	T1
	Hydrogen Cyanide	1000	538	T1		Toluene	896	480	T1
	Hydrogen Sulfide	500	260	T2B		Vinyl Acetate	756	402	T2
	2-Nitropropane	802	428	T2		Vinyl Chloride	882	472	T1
	Tetrahydrofuran	610	321	T2		Xylenes	867-984	463-528	T1
D	Acetic Acid (Glacia)	867	463	T1					
	Acetone	869	465	T1	<b>CLASS II – HAZARDOUS DUST ATMOSPHERES</b>				
	Ammonia, Anhydrous	1204	651	T1	Group	Material	Ignition Temp.		NEC Code
	Benzene	928	498	T1			°F	°C	
	Butane	550	287	T2A	E	Aluminum, A422 Flake	608	320	T2
	1-Butanol (Butyl Alcohol)	650	343	T2		Calcium Silicide	1004	540	T1
	2-Butanol (Secondary Butyl Alcohol)	761	405	T2		Manganese	464	240	T2C
	Ethane	882	472	T1		Magnesium, Grade B, Milled	806	430	T2
	Ethanol (Ethyl Alcohol)	685	363	T2	F	Charcoal	356	180	T3A
	Ethyl Acetate	800	427	T2		Coal, Kentucky Bituminous	356	180	T3A
	Ethylene Dichloride	775	413	T2		Coal, Pittsburgh Experimental	338	170	T3B
	Gasoline (56-60 Octane)	536	280	T2A		Pitch, Petroleum	1166	630	T1
	Gasoline (100 Octane)	853	456	T1	G	Alkyl Ketone Dimer Sizing Compound	320	160	T3C
	Heptanes	399	204	T3		Corn	482	250	T2C
	Hexanes	437	235	T2D		Corn Starch, Modified	392	200	T3
	Isoprene	428	220	T2D		Polyurethane Foam, Fire Retardant	734	390	T2
	Isopropyl Ether	830	443	T2		Shellac	752	400	T2
	Methane (Natural Gas)	900-1170	482-632	T1		Soy Flour	374	190	T3A
	Methanol (Methyl Alcohol)	867	464	T1		Sugar, Powdered	698	370	T2
	3-Methyl-1-Butanol (Isoamyl Alcohol)	662	350	T2		Sulfur	428	220	T2D
	Methyl Ethyl Ketone	759	404	T2		Wheat	428	220	T2D
						Wood Flour	500	260	T2B

The materials given are found in NEPA 497M, 1991 and NFPA 325, 1994.

# Explosion-proof Duct Heaters

## Engineering Information

### National Electrical Code Requirements for Duct Heaters

In addition to the general requirements for hazardous areas on pages 45 and 46, the NEC also requires that all duct heaters have built-in protection against low airflow, primary and secondary overtemperature protection, and overcurrent protection for heaters drawing more than 48 amps. These safety features are provided with all INDEECO explosion-proof duct heaters.

## Airflow Requirements

Airflow must be calculated to give the required temperature rise and to ensure sufficient airflow to prevent the thermal cutouts from tripping prematurely.

**Required air volume** to give the desired temperature rise for a given KW is determined by the formula:  
 $SCFM = KW \times 3193 / \Delta T$  where SCFM is airflow volume in Standard Cubic Feet per Minute and  $\Delta T$  is temperature rise in °F.

**Minimum air velocity** for safe operation is determined by dividing the heater KW by the cross-sectional duct area:  
 $KW / Sq. Ft. = KW / (W \times H / 144)$  where W and H are duct width and height in inches. For ULTRA-SAFE™ duct heaters, use the minimum W x H dimensions shown in the Heater Listing on page 51. Read the minimum velocity from the horizontal axis of Figure 72A for ULTRA-SAFE™ Duct Heater or Figure 72B for Series EP2 heaters.

**Airflow must be uniform** over the face of the heater, and must be horizontal for all but Custom Explosion-proof Duct Heaters.

**Horizontal airflow direction** is defined in Figure 72C.

**Pressure drop** through the heater can be determined by using figure 72D for the ULTRA-SAFE™ duct heater.

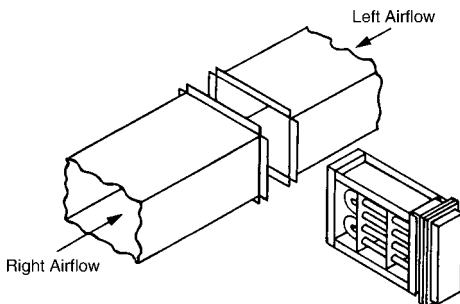

Figure 72C.

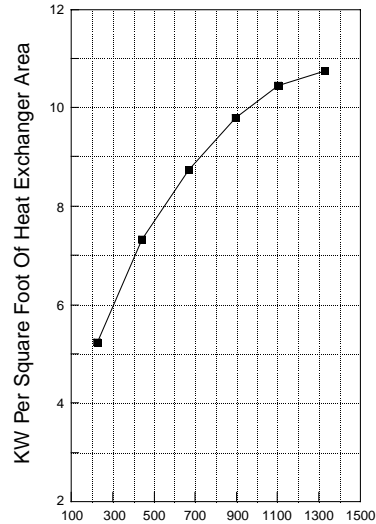

Figure 72A. Minimum air velocity required for ULTRA-SAFE™, feet per minute (meters per minute)

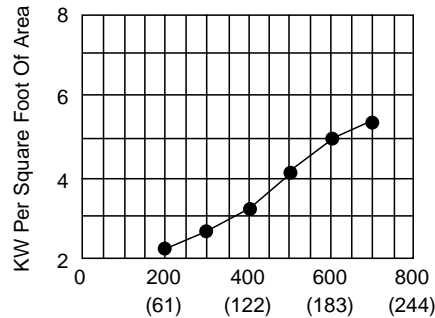

Figure 72B. Minimum air velocity required for EP2 feet per minute (meters per minute)

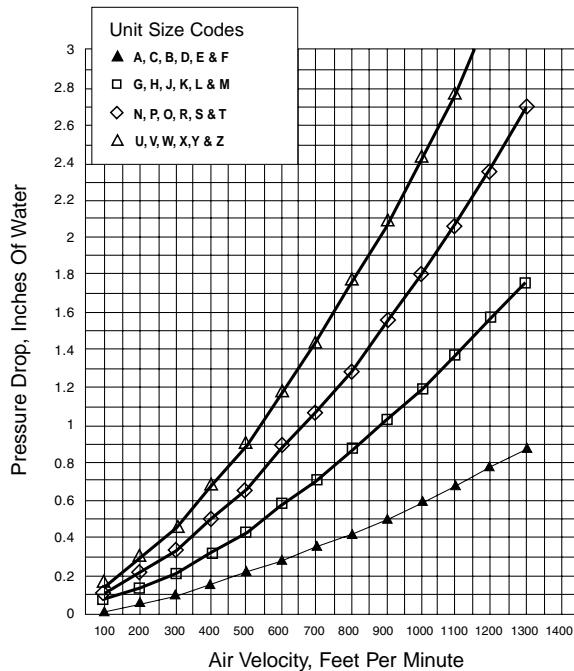

Figure 72D. ULTRA-SAFE™ Pressure Drop Curve

# Explosion-proof Duct Heaters

Engineering developments at INDEECO have made electric duct heaters for hazardous locations readily available at affordable prices.

## ULTRA-SAFE™

- FM and CSA Approved for virtually all Class I and Class II, Division 1 and 2 hazardous gas or dusty atmospheres
- Ignition temperatures as low as 320°F (160°C)
- Six standard sizes to fit a wide range of ducts
- Ratings up to 240 KW, 600 volts

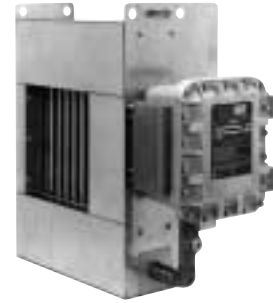

Figure 73. ULTRA-SAFE™ Explosion-proof Duct Heater

## Series EP2

- FM and CSA Approved for Class I, Division 2 locations where a hazardous gas is occasionally present
- Ignition temperatures as low as 392°F (200°C)
- For ducts up to 240" (610 cm) wide by 120" (305 cm) high
- Ratings up to 1000 KW, 600 volts

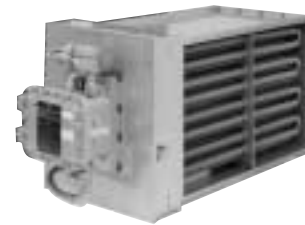

Figure 74. EP2 Explosion-proof Duct Heater

## Custom

- Wider range of sizes than available in the other two designs
- Vertical airflow
- Ratings up to 750 KW, 600 volts



Figure 75. Custom Explosion-proof Duct Heater

Table XVIII

Comparison Chart

Heater Type	KW and Control Range	Class and Division	NEC Ignition Temperature Code	Special Considerations
<b>ULTRA-SAFE™</b> For hazardous gas or dust atmospheres. Fits ducts from 12"W x 12"H to 75"W x 35"H.	Up to 240 KW  Single stage or SCR Control	Class I, Divisions 1 and 2, Groups B, C and D  Class II, Divisions 1 and 2, Groups E, F and G	T3C 320°F (160°C)	<ul style="list-style-type: none"> <li>• Fastest delivery of the three designs</li> <li>• Available for outdoor or wet locations</li> <li>• Corrosion resistant construction available</li> <li>• Horizontal airflow only</li> <li>• Not approved for shipboard use</li> </ul>
<b>Series EP2</b> For Division 2 hazardous gases (hazard exists only occasionally).	Up to 1000 KW  Multi-stage or SCR Control	Class I, Division 2, Groups C and D	T3 392°F (200°C)	<ul style="list-style-type: none"> <li>• Available for outdoor or wet locations</li> <li>• May be less expensive than ULTRA-SAFE™ for larger KW designs</li> <li>• Horizontal airflow only</li> <li>• Approved for shipboard use</li> </ul>
<b>Custom</b> Designed for each project. Not FM or CSA Approved.	Up to 750 KW  Multi-stage or SCR Control	Class I, Divisions 1 and 2, Groups C and D  Class II, Divisions 1 and 2, Groups E, F and G	T1 842°F (450°C) through T3B 329°F (165°C)	<ul style="list-style-type: none"> <li>• Horizontal or vertical airflow</li> <li>• Slip-in or flanged mounting</li> <li>• For ducts smaller than 12" x 12"</li> <li>• Available for outdoor or wet locations</li> </ul>